

ALLEY WITH NORMAL CROWN

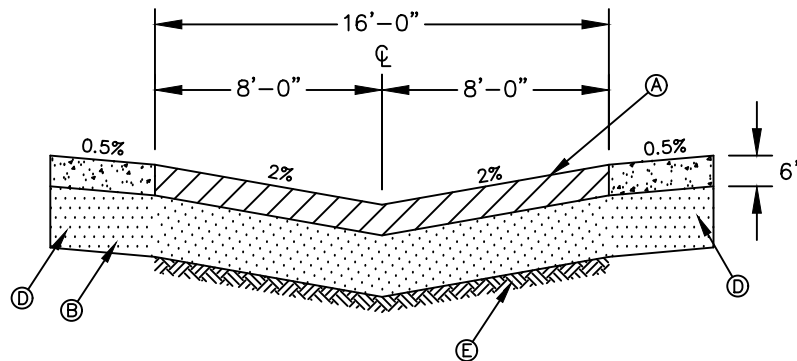

ALLEY WITH INVERSE CROWN

PAVEMENT SCHEDULE

- A. 2" S9.5C SURFACE COURSE
- B. 8" AGGREGATE BASE COURSE OR 4" B25.0C BASE COURSE
- C. 2'-0" VALLEY GUTTER
- D. 1'-0" X 6" CONCRETE STRIP
- E. SUBGRADE COMPACTED TO PUBLIC STREET STANDARDS

NOTES:

1. ALLEYS SHALL BE CONSIDERED PRIVATE AND WILL NOT BE ACCEPTED FOR MAINTENANCE BY THE CITY OF KANNAPOLIS.
2. TYPICAL SECTION APPLIES TO SINGLE/DOUBLE LOADED ALLEYS. FOR SINGLE-LOADED ALLEYS, THERE SHALL BE A 20-FOOT CLEAR ZONE FREE OF OBSTRUCTIONS FROM THE LOADED SIDE EDGE OF PAVEMENT.
3. MINIMUM 20' WIDE PAVEMENT REQUIRED IF ALLEY IS TO BE CONSIDERED A "FIRE APPARATUS ACCESS ROAD" PER NC FIRE CODE. FIRE CODE MAY REQUIRE OTHER DIMENSIONAL AND PAVEMENT SECTION CHANGES TO ACCOMMODATE MINIMUM REQUIREMENTS.

NOT TO SCALE