

ELEVATION VIEW

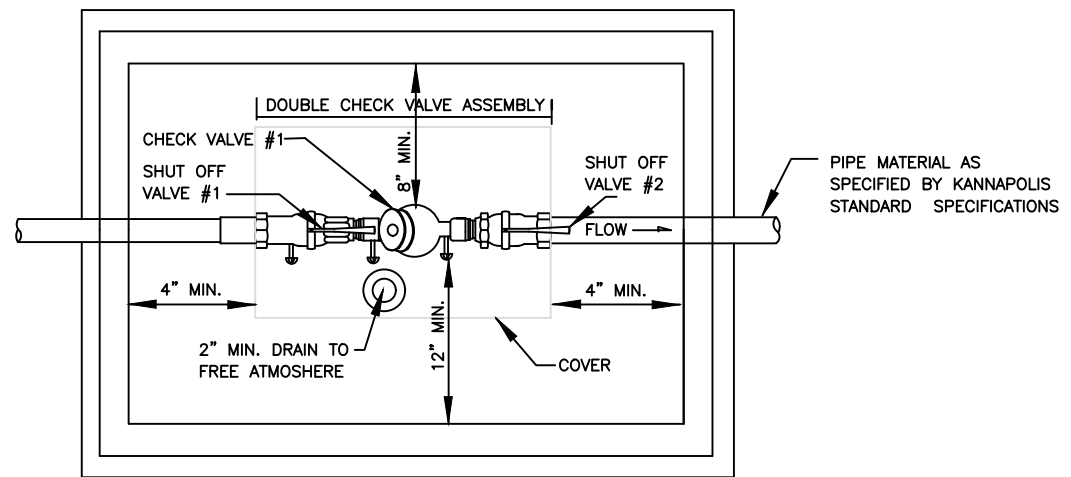

PLAN VIEW

NOT TO SCALE

NOTES:

1. DCVA MUST CONFORM TO CITY OF KANNAPOLIS SPECIFICATIONS FOR BACKFLOW PREVENTION ASSEMBLIES 3/4"-2".
2. KANNAPOLIS APPROVED DCVA'S INCLUDE SHUT OFF VALVE #1 AND VALVE #2 NO SUBSTITUTION SHALL BE PERMITTED.
3. VAULT, DOORS OR COVERS AND SUPPORT OF ASSEMBLY SHALL BE DESIGNED BY OWNER AND AS REQUIRED.
4. IF DRAINAGE CANNOT BE PROVIDED TO FREE ATMOSPHERE OR STORM DRAINAGE, THE DCVA'S SHALL BE INSTALLED ABOVE GROUND.
5. TEST COCK #1 SHALL BE UPSTREAM OF SHUT OFF VALVE #1 AND IS PART OF THE APPROVED ASSEMBLY.
6. SEE CITY OF KANNAPOLIS LAND DEVELOPMENT STANDARDS MANUAL APPENDIX B FOR LIST OF APPROVED PRODUCTS.